



SPECIFICATION OF SR TYPE SPEED CONTROL MOTORS

SIZE mm sq.	Motor Type	Controller Type	Poles	Output (w)	Voltage (V)	Freq. (Hz)	Duty	Speed Range (rpm)	Permissible Torque				Starting Torque		Cap. (μF)
									at 1200rpm		at 90rpm		(kg-cm)	(N-m)	
70	S7R15GA-ES12 S7R15GA-ES12(TP) S7R15GA-ES12CE	SRA02 SRA02CE	4	15	1 ∅ 110	60	30min.	90-1700	1.40	0.140	0.70	0.070	1.30	0.130	6.0
	S7R15GB-ES12 S7R15GB-ES12(TP) S7R15GB-ES12CE	SRB02 SRB02CE	4	15	1 ∅ 220	60	30min.	90-1700	1.40	0.140	0.70	0.070	1.30	0.130	1.5
	S7R15GC-ES12 S7R15GC-ES12(TP) S7R15GC-ES12CE	SRC02 SRC02CE	4	15	1 ∅ 100	50 60	30min.	90-1400 90-1700	1.10 0.90	0.110 0.090	0.60	0.060	1.00	0.100	6.0
	S7R15GD-ES12 S7R15GD-ES12(TP) S7R15GD-ES12CE	SRD02 SRD02CE	4	15	1 ∅ 200	50 60	30min.	90-1400 90-1700	1.10 0.90	0.110 0.090	0.60	0.060	1.00	0.100	1.5
	S7R15GX-ES12 S7R15GX-ES12CE	SRX02 SRX02CE	4	15	1 ∅ 220 1 ∅ 240	50	30min.	90-1400	1.00 1.15	0.100 0.115	0.55 0.60	0.055 0.060	0.90 1.00	0.090 0.100	1.2

- ❖ CE marked at the end of motor model name indicates that it is thermally protected type which has received CE.
- ❖ SR type controller model with "CE" appeared at the end of motor model name indicates that the product acquired CE MARK certification.
- ❖ TP marked at the end of the motor model name indicates that it is standard motor with Thermal Protector mounted.
S7R15GX-ES12, S7R15GX-ES12CE is thermally protected type with TP mounted.
- ❖ "L" or "H" type does not apply to motors under 40W.

SPECIFICATION OF SS TYPE SPEED CONTROL MOTORS

SIZE mm sq.	Motor Type	Controller Type	Poles	Output (w)	Voltage (V)	Freq. (Hz)	Duty	Speed Range (rpm)	Permissible Torque				Starting Torque		Cap. (μF)
									at 1200rpm		at 90rpm		(kg-cm)	(N-m)	
70	S7R15GA-ES24 S7R15GA-ES24(TP) S7R15GA-ES24CE	SSA02-SRSS SSA03-SRSS	4	15	1 ∅ 110	60	30min.	90-1700	1.40	0.140	0.70	0.070	1.30	0.130	6.0
	S7R15GB-ES24 S7R15GB-ES24(TP) S7R15GB-ES24CE	SSB02-SRSS SSB03-SRSS	4	15	1 ∅ 220	60	30min.	90-1700	1.40	0.140	0.70	0.070	1.30	0.130	1.5
	S7R15GC-ES24 S7R15GC-ES24(TP) S7R15GC-ES24CE	SSC02-SRSS SSC03-SRSS	4	15	1 ∅ 100	50 60	30min.	90-1400 90-1700	1.10 0.90	0.110 0.090	0.60	0.060	1.00	0.100	6.0
	S7R15GD-ES24 S7R15GD-ES24(TP) S7R15GD-ES24CE	SSD02-SRSS SSD03-SRSS	4	15	1 ∅ 200	50 60	30min.	90-1400 90-1700	1.10 0.90	0.110 0.090	0.60	0.060	1.00	0.100	1.5
	S7R15GX-ES24 S7R15GX-ES24CE	SSX02-SRSS SSX03-SRSS	4	15	1 ∅ 220 1 ∅ 240	50	30min.	90-1400	1.00 1.15	0.100 0.115	0.55 0.60	0.055 0.060	0.90 1.00	0.090 0.100	1.2

- ❖ CE marked at the end of motor model name indicates that it is thermally protected type which has received CE.
- ❖ TP marked at the end of the motor model name indicates that it is standard motor with Thermal Protector mounted.
S7R15GX-ES24, S7R15GX-ES24CE is thermally protected type with TP mounted.
- ❖ "L" or "H" type does not apply to motors under 40W.

50Hz

GEAR RATIO		3	3.6	5	6	7.5	9	10	12.5	15	18	20	25	30	36	40	50	60	75	90	100	120	150	180	200
MODEL	rpm	500	416	300	250	200	166	150	120	100	83	75	60	50	41	37	30	25	20	16	15	12	10	8	7.5
	kg·cm	3.2	3.9	5.4	6.5	8.1	9.7	10.8	13.5	16.2	19.4	19.4	24.2	29.1	34.9	38.8	43.6	50.0	50.0	50.0	50.0	50.0	50.0	50.0	50.0
S7KA□B	N·m	0.314	0.382	0.530	0.637	0.794	0.951	1.059	1.324	1.587	1.902	1.902	2.373	2.854	3.423	3.805	4.276	4.900	4.900	4.900	4.900	4.900	4.900	4.900	4.900

60Hz

GEAR RATIO		3	3.6	5	6	7.5	9	10	12.5	15	18	20	25	30	36	40	50	60	75	90	100	120	150	180	200
MODEL	rpm	600	500	360	300	240	200	180	144	120	100	90	72	60	50	45	36	30	24	20	18	15	12	10	9
	kg·cm	3.0	3.6	5.1	6.1	7.6	9.1	10.1	12.7	15.2	18.2	18.2	22.8	27.3	32.8	36.5	41.0	49.2	50.0	50.0	50.0	50.0	50.0	50.0	50.0
S7KA□B	N·m	0.294	0.353	0.500	0.598	0.745	0.892	0.990	1.245	1.491	1.785	1.785	2.236	2.677	3.217	3.579	4.021	4.825	4.900	4.900	4.900	4.900	4.900	4.900	4.900

- ❖ The code in □ of gearhead model is for gear ratio.
- ❖ It is the permissible torque of the assembled motor and gearhead.
- ❖ ■ color indicates that the output shaft of the geared motor rotates in the same direction as the output shaft of the motor. Others indicate rotation in the opposite direction.
- ❖ Rpm is based on synchronous speed (50Hz: 1500rpm, 60Hz: 1800rpm) divided by gear ratio. The actual rotation speed can be 2~20% less than displayed value depending on the load.
- ❖ "L" or "H" type does not apply to motors under 40W.

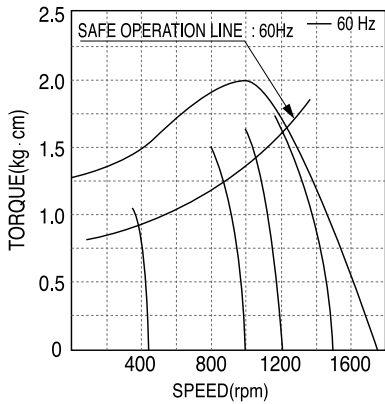

- ▲ S7R15GA-ES12 S7R15GA-ES24
- S7R15GA-ES12(TP) S7R15GA-ES24(TP)
- S7R15GA-ES12CE S7R15GA-ES24CE
- S7R15GB-ES12 S7R15GB-ES24
- S7R15GB-ES12(TP) S7R15GB-ES24(TP)
- S7R15GB-ES12CE S7R15GB-ES24CE

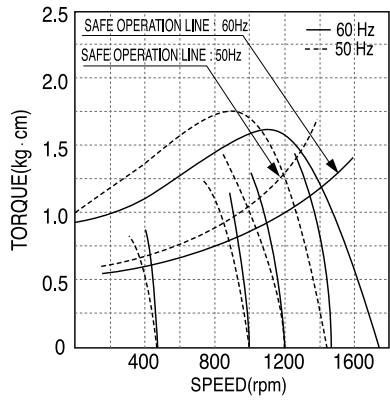

- ▲ S7R15GC-ES12 S7R15GC-ES24
- S7R15GC-ES12(TP) S7R15GC-ES24(TP)
- S7R15GC-ES12CE S7R15GC-ES24CE
- S7R15GD-ES12 S7R15GD-ES24
- S7R15GD-ES12(TP) S7R15GD-ES24(TP)
- S7R15GD-ES12CE S7R15GD-ES24CE

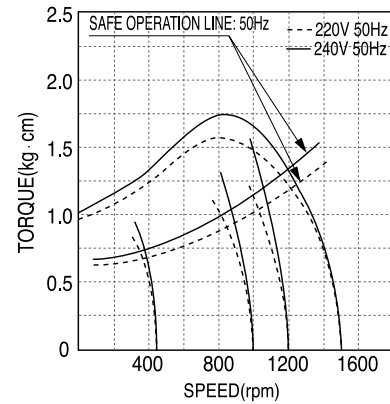

- ▲ S7R15GX-ES12 S7R15GX-ES24
- S7R15GX-ES12CE S7R15GX-ES24CE

DIMENSIONS

+ GEARED MOTOR

※ MOTOR MODEL : S7R15G□-ES12, S7R15G□-ES24
 ※ HEAD MODEL : S7□A3□~S7□A200□

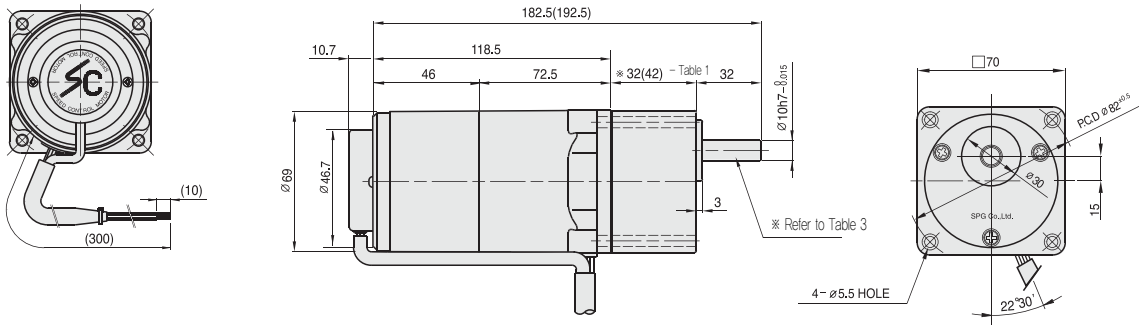

+ MOTOR

※ MOTOR MODEL : S7R15□□-ES12, S7R15□□-ES24

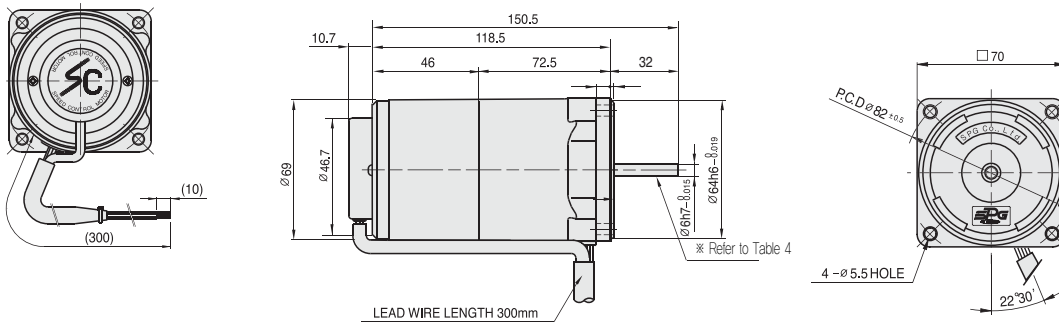

+ INTER-DECIMAL GEAR HEAD

※ MODEL : S7GX10B

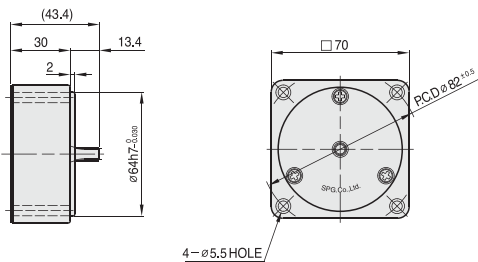

+ KEY SPEC

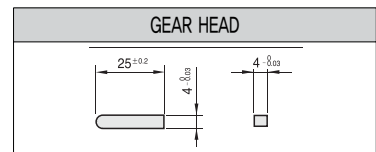

+ ※32(42) - (Table 1)

GEAR RATIO	SIZE(mm)
S7□A3□ ~ S7□A18□	32
S7□A20□ ~ S7□A200□	42

+ WEIGHT - (Table 2)

PART	WEIGHT(kg)	
MOTOR	1.04	
DECIMAL GEAR HEAD	0.32	
GEAR HEAD	S7□A3□ ~ S7□A18□	0.38
	S7□A20□ ~ S7□A40□	0.47
	S7□A50□ ~ S7□A200□	0.52

+ SPEC for output shaft of gearhead - (Table 3)

MODEL	TYPES OF OUTPUT SHAFT
S7SA3□ ~ S7SA200□	STRAIGHT TYPE
	D-CUT TYPE
S7DA3□ ~ S7DA200□	STRAIGHT TYPE
	D-CUT TYPE
S7KA3□ ~ S7KA200□	KEY TYPE
	D-CUT TYPE

+ SPEC for output shaft of motor - (Table 4)

MODEL	TYPES OF OUTPUT SHAFT
S7R15G□-ES12 S7R15G□-ES24	GEAR TYPE
	STRAIGHT TYPE
S7R15D□-ES12 S7R15D□-ES24	STRAIGHT TYPE
	D-CUT TYPE